

## OPTi drill® DX 13V / DX 15V

### Table drilling machine with continuously adjustable speed control

#### Facts that impress in terms of quality, performance and price

- ▶ Best possible force transmission thanks to aluminium pulleys
- ▶ Digital speed display integrated in housing, speed control via potentiometer
- ▶ Emergency stop button
- ▶ Drill spindle with precision ball bearings
- ▶ Premium OPTIMUM quick clamping chuck as standard
- ▶ Guaranteed concentricity less than 0.03 mm measured at the drilling spindle sleeve
- ▶ Height adjustability chuck guard with microswitch
- ▶ Membrane keyboard, dirt/water-resistant, easy to clean
- ▶ Precision drilling table with parallel T-slots
- ▶ Thick walled cast column for high force absorption and stability
- ▶ Solid baseplate with, pronounced ribbing on rear
- ▶ EMC filter class C2

#### DX 13V

- ▶ Drill head height adjustable

#### DX 15V

- ▶ Drilling table height-adjustable via rack
- ▶ MT Adapter



Fig.: DX 13V

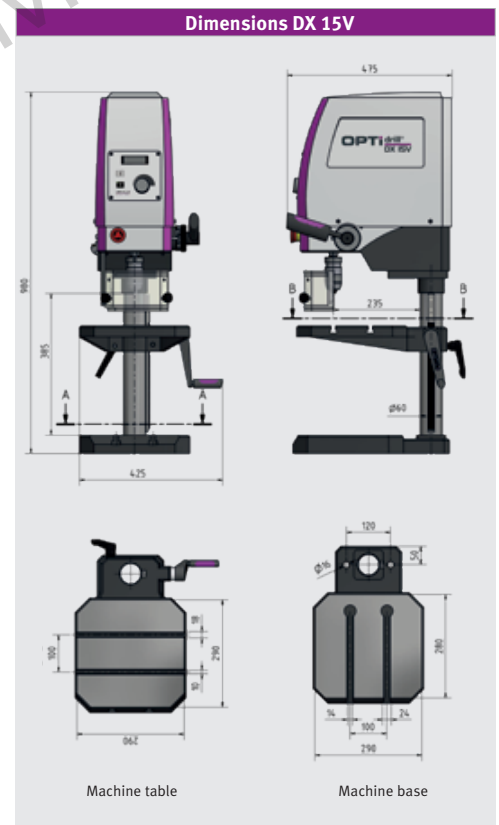
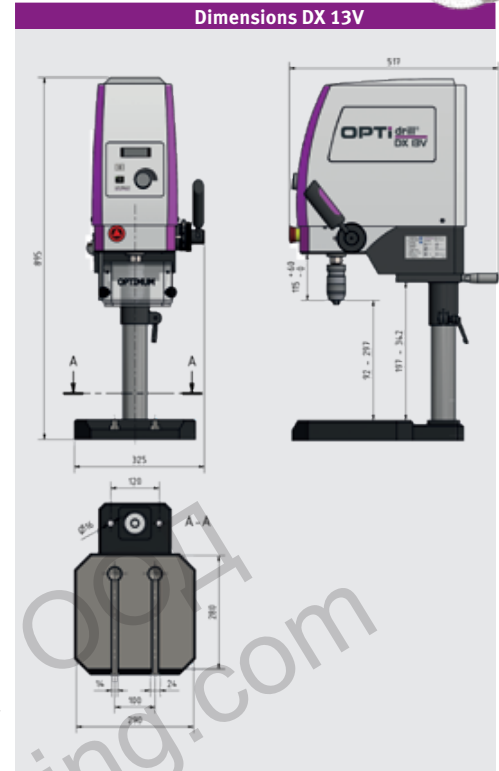

Fig.: DX 15V

## Technical specifications, accessories and dimensions



Model	DX 13V	DX 15V
Article no.	3020150	3020155
<b>Technical specifications</b>		
Electrical connection	230 V / 1 Ph ~50 Hz	
Motor output	0.85 kW	
<b>Drilling performance</b>		
Drilling performance in steel (S235JR)	Ø 13 mm	Ø 15 mm
Continuous drilling performance in steel (S235JR)	Ø 11 mm	Ø 12 mm
<b>Spindle</b>		
Spindle sleeve stroke	60 mm	
Spindle seat	B 16	MT 2
Throat	235 mm	
<b>Speeds</b>		
Spindle speeds	100 - 3 000 rpm	
Number of speeds	Electronically controlled	
<b>Drilling table</b>		
Drilling table workspace L x W	-	290 x 290 mm
T-slot size / spacing / count	-	10 mm / 100 mm / 2
Rotating drilling table	-	360°
Clearance chuck - drilling table	-	98 - 375 mm
<b>Machine base</b>		
Machine base work area L x W	280 x 290 mm	290 x 280 mm
T-slot size / spacing / count	14 mm / 100 mm / 2	
Distance chuck - machine base	92 - 297 mm	290 - 355 mm
<b>Dimensions</b>		
Column diameter	Ø 60 mm	
Length x width x height	325 x 517 x 895 mm	425 x 475 x 980 mm
Weight	51 kg	66 kg



Accessories	Article no.
Twist drill bits HSS-CO 5%, 25 parts	3201010
Twist drill bits HSS-CO 5%, 51 parts	3201020
Twist drill bits HSS-CO 5%, 41 parts	3201021
T-slot nut (individual) M12 / 14 mm	3353025
Assortment of clamping tools size 12, 58-parts	3352017
Blank holder 14 mm/M12	3352031
Universal coolant unit	3352002
Coolant mist lubricator MMC 1 with magnetic holder	3356663
Coolant hose KMS 2	3356660
Machine chassis	3353000
Information „Machine bases“ on page 135	

Accessories DX 15V	Article no.
Twist drill HSS MT 2	3051002
Quick release chuck direct MT 2 / 1 - 16 mm	3050571
Quick release chuck direct MT 2 / 1 - 13 mm	3050572
Morse taper MT 2/B16	3050659
T-slot nut (individual) M 8 / 10 mm	3353022
Assortment of clamping tools size 8, 58-parts	3352015
Thread tapping chuck 6 inserts, sizes M3 - M12	3050702
Thermdrill MT 2	3060005

Machine vices	Article no.
BMS 85	3000008
BMS 100	3000010
BMS 120	3000012
BSI 100	3000210
BSI-Q 100	3000230

> Information on the vises on page 71

### Scope of supply

> Quick-action drill chuck 1 - 13 mm